



## Features

- Absolute smoke detection
- Wide sensitivity range
- Single pipe inlet
- Five (5) status LEDs
- Referencing
- VESDAnet communication (VN)
- Dual stage dust filter
- Three (3) Alarm Levels
- Three (3) Programmable Relays
- Air flow monitoring
- Optional remote display and relay capability
- Simple mounting design
- AutoLearn™

## Approvals/Listings

- Bureau Veritas 15341/A0 BV
- Lloyd's Register 05/00087

## Introduction

The LaserCOMPACT detector has been tested and certified to provide all the benefits of aspirating smoke detection, including very early warning, in Marine Environments. This has been achieved through additional testing to ensure the ongoing performance of the product in challenging marine applications.

The Marine products have been approved by Bureau Veritas\* and Lloyd's Register\*\*. They are rated IP30 so, where applicable, it is recommended that the detector is housed in an IP66 enclosure.

As with the standard LaserCOMPACT, the Marine version combines the well-proven LaserPLUS detection technology, dual-stage air filtration technology and a modified aspirator design, and incorporates them into a compact enclosure with a simplified display.

## Two variants and a remote display option

The Marine version of the LaserCOMPACT is available in two versions, one that interfaces via relays only (RO) and one that interfaces via relays and VESDAnet (VN). The VN version is compatible with the marine version of the remote Display Module, which allows the current status of the detector to be reported in the most convenient location (such as the bridge).

The remote Display Module has 7 remote relays to support any combination of signalling that may be demanded by the application. The VN version allows several detectors to be linked together on VESDAnet thereby allowing one to act as a reference detector for other VESDA detectors.

## Description

The LaserCOMPACT is made up of two parts: the main enclosure and the front cover. The main enclosure houses all the key components of the detector. All non-serviceable items like the main processor board and detector chamber are mounted away from the general access area, protecting them during the installation and service process.

The front cover includes:

- 5 LEDs: Fire, Pre-Alarm/Alert, Fault, OK, Reset/Isolate
- Reset/Isolate Push Button (press to reset, press and hold to isolate)

\* Bureau Veritas

Approved for use in Bridge & Deck zones as defined in the BV Rules for the Classification of Steel Ships.

\*\* Lloyd's Register

Applications defined as Marine, offshore and industrial use in environmental categories ENV1, ENV2 and ENV3 as described in Lloyd's Register Test Specification No. 1:2002. The specified standard to which the type approval relates is CEA 4022:1999.



## How it works

Air is continually drawn through a simple pipe network to a central detector by a high efficiency aspirator. Air entering the unit passes a flow sensor before a sample is passed through a dual-stage dust filter (the majority of air is exhausted from the detector and where required back vented to the protected area). The first stage removes dust and dirt from the air sample before it enters the chamber for smoke detection. The second ultra fine stage provides a clean air supply to be used inside the detection chamber to form clean air barriers, which protect the optical surfaces from contamination.

The detection chamber uses a stable, highly efficient laser light source and unique sensor configuration to achieve the optimum response to a wide range of smoke types. When smoke passes through the detection chamber it creates light scatter which is detected by the very sensitive sensor circuitry.

The status of the detector, all alarms, service and fault events, are monitored and logged with time and date stamps. Status reporting can be transmitted via simple relay connections or across the advanced VESDAnet communications network (VN version only).

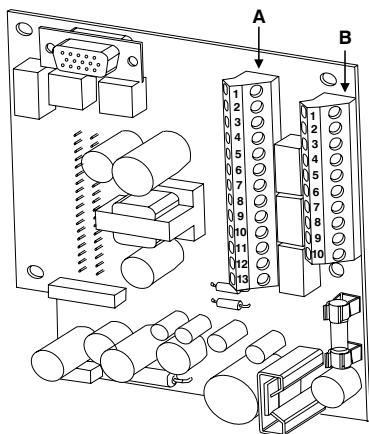

### LaserCOMPACT Termination Card (VN)

Terminal A	Terminal B
1 Bias (-) (GND)	1 Shield
2 Reset (-)	2 VESDAnet-A (-)
3 Reset (+)	3 VESDAnet-A (+)
4 Bias (+)	4 Shield
5 LED (-) (GND)	5 VESDAnet-B (-)
6 LED (+)	6 VESDAnet-B (+)
7 FIRE (NO)	7 Power (-)
8 FIRE (C)	8 Power (+)
9 PRE-ALARM (NO)	9 Power (-)
10 PRE-ALARM (C)	10 Power (+)
11 FAULT (NO)	
12 FAULT (C)	
13 FAULT (NC)	

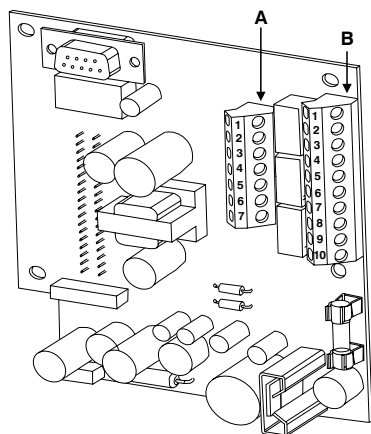

### LaserCOMPACT Termination Card (RO)

Terminal A	Terminal B
1 FIRE (NO)	1 Bias (-) (GND)
2 FIRE (C)	2 Reset (-)
3 PRE-ALARM (NO)	3 Reset (+)
4 PRE-ALARM (C)	4 Bias (+)
5 FAULT (NO)	5 LED (-) (GND)
6 FAULT (C)	6 LED (+)
7 FAULT (NC)	7 Power (-)
	8 Power (+)
	9 Power (-)
	10 Power (+)

## Ordering Information

### Product

VESDA LaserCOMPACT – Marine VN  
VESDA LaserCOMPACT – Marine RO  
Remote Display – LaserCOMPACT Marine

### Part number

VLC-50500-MRN  
VLC-50000-MRN  
VRT-J0000-MRN

## Specifications

### Supply voltage:

18 to 30VDC

### Power consumption:

5.4W quiescent, 5.9W with alarm

### Current consumption:

225mA quiescent, 245mA with alarm

### Fuse rating:

1.6A

### Dimensions (WHD):

225mm x 225mm x 85mm (8 7/8" x 8 7/8" x 3 3/8")

### Weight:

1.9kg (4.2lbs.)

### Operating conditions:

Tested to -25°C to 70°C (-13°F to 158°F)  
Detector Ambient 5°C to 70°C (41°F to 158°F)  
(recommended)

Sampled Air -20°C to 60°C (-4°F to 140°F)

Humidity 10 to 95% RH, non-condensing

Approved for use in bridge and deck zones, and ENV3 environments

Exposure to corrosive atmosphere may invalidate warranty

### Sampling network:

Maximum area of Coverage 800sq.m (8000sq.ft)

### Maximum pipe lengths:

1 x 80m, 2 x 50m

### Computer design tool:

ASPIRE2™

### Pipe:

Internal Diameter 15–21mm (9/16"–7/8")

External Diameter 25mm (1")

### Relays:

3 Relays rated 2A @ 30VDC

Fire (NO)

Pre-Alarm (NO)

Alert/Fault (Maintenance & Isolate) (NC/NO)

Configurable as latching or non-latching

### IP rating:

IP30

### Cable access:

4 x 25mm (1") cable entries

### Cable termination:

Screw Terminal blocks 0.2-2.5sq mm (30-12 AWG)

### Sensitivity range:

0.005 to 20% obs/m (0.0015 to 6.25% obs/ft)

### Threshold setting range:

Alert: 0.005–1.990% obs/m  
(0.0015–0.6218% obs/ft)

Pre-Alarm: 0.010–1.995% obs/m  
(0.0031–0.6234% obs/ft)

Fire: 0.015–20.00% obs/m  
(0.0046–6.25% obs/ft)

### Software features:

Event log: Up to 12,000 events stored on FIFO  
Smoke level, alarms and faults with time and date stamp

AutoLearn: Minimum 15 minutes, maximum 15 days.  
Recommended minimum 14 days.

During AutoLearn thresholds are NOT changed from pre-set values.

### Configurable general input (24VDC):

Standby, Mains OK or Reset/Isolate

### The Americas

Vision Systems  
700 Longwater Drive  
Norwell Massachusetts  
02061 USA  
Ph 1 781 740 2223  
Toll Free 1 800 229 4434  
Fax 1 781 740 4433

### Australia and Asia

Vision Systems  
495 Blackburn Road  
Mount Waverley VIC 3149  
Australia  
Ph +61 3 9211 7200  
Fax +61 3 9211 7202

### Europe and the Middle East

Vision Systems  
Vision House  
Focus 31 Mark Road  
Hemel Hempstead  
Herts HP2 7BW UK  
Ph +44 1442 242 330  
Fax +44 1442 249 327

### Online

www.vision-fs.com

The manufacturer reserves the right to change designs or specifications without obligation and without further notice. VESDA, LaserTEKNIC, LaserPLUS, LaserSCANNER, LaserCOMPACT, LaserFOCUS, VESDAnet, VESDAlink, ASPIRE, ASPIRE2, AutoLearn, VSM, VConfig, InfoWORKS, PROACTIV, PRECISION, VSC, ADPRO, FastTrace, FastVu, FastScan, Axiom, PRO, Amux and Video Central are trade marks used under licence by the distributor. This document is protected by copyright under the laws of Australia and other jurisdictions throughout the world. It must not by any means, either in whole or part, be reproduced, communicated to the public, adapted, distributed, sold, modified, published except as permitted by any laws or statute or with prior written consent of VFS International Pty Ltd. Copyright © 2005 VFS International Pty Ltd ACN 100 259 381.

