



MINERVA® MX 801PC 3oTec Detector

Features:

- Combined optical, heat and carbon monoxide detector
- LPCB and VdS approved fire detector (pending)
- EN50291 CO toxic gas detector
- Operate simultaneously as a fire detector and CO toxic gas detector
- Early detection of all fire types from slow smouldering to fast flaming
- Minerva® Expert algorithms use all three elements for positive false alarm free fire detection
- Optical, CO and Heat can operate independently for sequential alarm systems and CO toxic gas alert
- All 3 elements are independently monitored for faults
- Universal mode for maximum protection
- Resilient mode for false alarm free operation in challenging environments
- Use with standard or loop powered sounder base for reduced installation costs
- MXDigital signalling suitable for most cable types including retro-fit

3oTec is an integrated Optical, Heat, and Carbon Monoxide (CO) detector that uses all three detection methods to deliver early fire detection and false alarm resistance. It uses sophisticated algorithms that analyze Smoke, Heat, and Gas to distinguish real fires from other false alarm causing culprits like shower steam and burnt toast.

Smoke, Heat and Gas inputs operate in concert to confirm the presence of a fire in the early stages far more quickly than any of the technologies operating individually. This innovative technology is important for detecting a wide range of fire types, especially those slow smoldering fires where smoke levels have been known to remain very low for several hours.

3oTec Operating Modes

- Universal Mode - EN54 pt.7 - CEA4021 - ISO7240.7
- Resilient Mode - EN54 pt.7 - CEA4021-ISO7240.7
- High Performance Optical - EN54 pt.7 - ISO7240.7
- Compensated CO Fire Sensing - LPS1265 - ISO7240.6
- Heat Detection - EN54 pt.5 A1R - ISO7240.5
- CO Toxic Gas Detection- EN50291

3oTec is a combined optical, carbon monoxide and heat detector for use with MX Technology[®] controllers. The 801PC can be used in combination with other MX Technology[®] detectors with a maximum total of 250 detectors connected to a single 2 wire MXDigital loop.

Heat Sensing Element

- High quality thermistor with very low thermal mass for added responsiveness

Optical Chamber

- The optical chamber has many advanced features that improve performance and reliability.
- High intensity, short pulse width infrared light source for heightened responsiveness.
- Optical feedback will verify the total optical path on every poll of the detector.
- Precision optics eliminate nuisance from small insects such as thrips, without the need for a filter.

Carbon Monoxide Cell

- High efficiency electro-chemical CO detection cell
- Cell integrity is continuously monitored
- Increased cell capacity for durability
- Cell electronically calibrated for ISO7240.6 fire applications or EN50291 toxic gas applications

Technical Specifications

Model 801PC

Mechanical

Detector Material	FR110 "Bayblend" Fire resistant
Dimensions	See diagram below
Weight	0.2Kg detector and base (approx)
Colour	White

Environmental

Operating Temp. Range	-10°C to +55°C
Storage Temp.	-20°C to +55°C
Relative Humidity	90% non condensing

Electrical

Loop Voltage	20-40V
Quiescent Current	300µA typical
Alarm Current	3mA typical
Wiring Connections	SEM Terminal 2 x 1.5mm ²

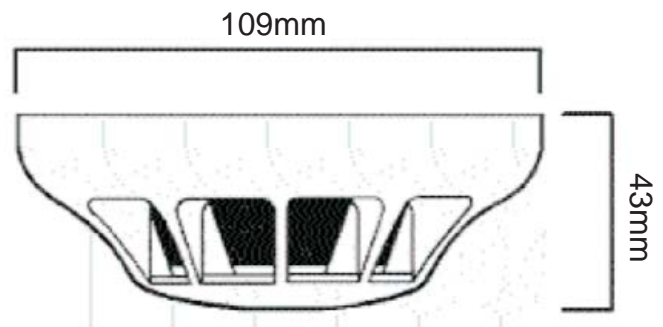

For further information on how we can help you, contact your local ADT office:

Austria - ADT Austria

Tel: 662 45 24 60 11
Website: www.adteurope.com

Belgium - ADT Security Services SA.

Tel: 02 481 08 00
Website: www.adt-belguim.be

Czech Republik - ADT Security Center s.r.o.

Tel: 267 267 267
Website: www.adt-sc.cz

Denmark - ADT A/S

Tel: 70 80 70 00
Website: www.adt-nordic.com

France - ADT France

Tel: 0810 000 260
Website: www.adtfrance.fr

Germany - ADT Security Deutschland GmbH

Tel: 0800 7070 238
Website: www.adt-deutschland.de

Greece - ADT Greece SA

Tel: 210 92 43 400
Website: www.adt.gr

Hungary - ADT Hungary

Tel: +3614303700
Website: www.adthungary.com

Ireland - ADT Fire and Security plc

Tel: 1620 5888
Website: www.adt.ie

Italy - ADT Italy

Tel: 02 818061
Website: www.adtitaly.com

The Netherlands - ADT Security Services B.V.

Tel: 010 258 4848
Website: www.adt-security.nl

Norway - ADT AS NUF

Tel: 81 55 88 88
Website: www.adt-nordic.com

Poland - ADT Poland Sp. z o.o.

Tel: 0 801 801 238
Website: www.adt.pl

Portugal - ADT Portugal

Tel: 217 510 560
Website: www.adt-pt.com

Russia - ADT Russia

Tel: +7 (495) 661 2094
Website: www.adtrussia.com

Spain - ADT Servicios de Seguridad SL

Tel: 902 444 440
Website: www.adt-es.com

Sweden - ADT AB

Tel: 8 40 00 70 00
Website: www.adt-nordic.com

Switzerland - ADT Switzerland

Tel: 0848 40 08 01
Website: www.adt-ch.com

United Kingdom - ADT Fire & Security plc

Tel: 0800 010 999
Website: www.adt.co.uk

