



MINERVA[®] MZX

MZX4000 Black Box Panel

Features:

- Two MZX Technology™ Detection loops as standard
- Expandable to 8 loops using the XLM800 Loop Expansion Cards
- Same Loop Power capability as standard MX4000 panel
- Reduces cost of a networked system
- Uses either the MXNet or FILNet Network (Network card supplied separately)
- Can be used to create a system of distributed loops to reduce installation costs
- Includes an Alarm, Fault, Power and System Fault Status Display
- Includes a single deep surface mount enclosure
- Includes an integral power supply and space for 38A/H Sealed Lead Acid Batteries
- Distributed Power Supplies reduce cabling costs
- Onboard dual sounder circuits
- Printer support provided at each black box
- Fully featured and supported remote bus at each black box - drives repeaters and mimic displays
- MZX Configurations may be downloaded at any black box or panel on the network
- Allows MINERVA[®] MZX detection panels to be expanded 2 to 8 loops at a time to provide large multi-loop panels
- Allows MINERVA[®] MZX detection panels to be located separately from their user interface

Black Box Panel

The MZX4000 Black Box Panel can be used to simplify larger networked systems by removing unnecessary multiple user interfaces. It consists of a 2 to 8 loop networked panel which does not have a user interface but uses a simple status display to indicate Alarm, Fault, Power and System Faults. It employs the user interface of another MZX Panel on the same network. The MZX4000 Black Box Panel is provided with 2 MZX detection loops as standard which can be expanded to 8 loops using the XLM800 Loop Expansion Card. It has the same loop power capability as the standard MX4000 panel complete with an integral power supply and space for 38A/H standby batteries, onboard dual sounder circuits, printer support and remote bus connection for repeater panels and mimic panels.

SPECIFICATIONS

Technical Specifications

Mechanical

Dimensions (HxWxD): 640 x 440 x 230 mm
 Approx. Weight: 16Kg

Colour

Housing: Dawn Grey (BS4800 10A-03)
 Front Cover: Dawn Grey (BS4800 10A-03)

Environmental

Operating Temperature: -8°C to +55°C
 Storage Temperature: -20°C to +70°C
 Relative Humidity: up to 95% RH (non condensing)
 EMC/RFI: EN50130-4 EN50081-1

Electrical

Supply Voltage: 120 to 240V a.c.
 Input Current: 0.8 to 2.2A

Ordering Information

Stockcode	Description
542.098	MZX4000/ZX4 Black Box Panel
557.202.007	XLM800 Loop Expansion Card
557.202.026	TLI800 MX Net Network Card

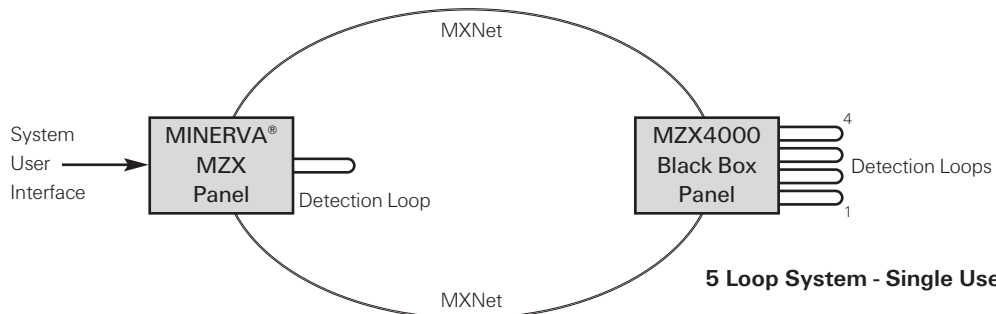

20 Loop System - Dual User Interface

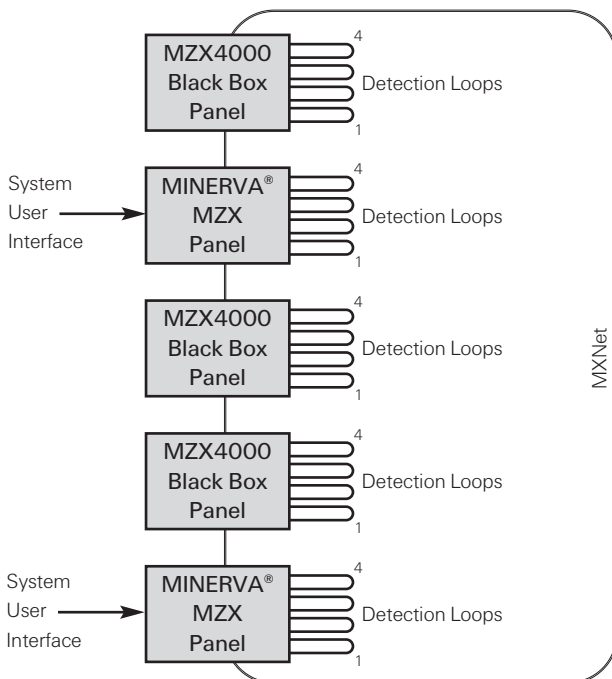

20 Loop System - Single User Interface

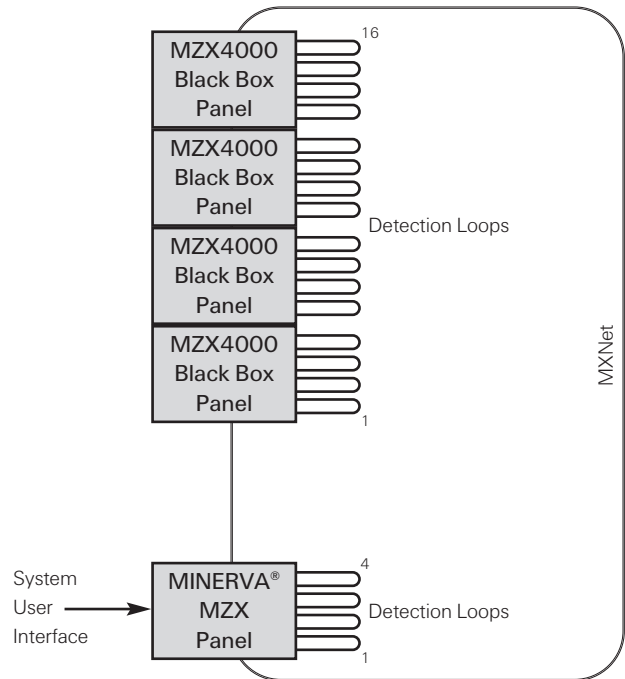

For further information on how we can help you, please visit our website at www.tycofis.com or e-mail us on tfis.fda.uk@tycoint.com.
 The right is reserved to modify or withdraw any product or service without notice. PSF134TFIS Issue 2 September 2009 © 2009