



MINERVA[®] MX

M600Ex Intrinsically Safe Fire Detectors

Features:

- Intelligent Universal Smoke/Heat/CO detector
- Low profile, discreet and unobtrusive
- Superior performance and reliability
- Designed for fast, easy installation
- Optional locking kit
- May be used in systems that meet BS5839 Pt 1
- Integral and remote alarm LED
- Certified to ATEX: Ex II 1GD and Cenelec: Ex ia IIC T5/Ex iaD 20 T100°C
- Complies to EN54-7 for Smoke Detectors and EN54-5 for Heat Detectors

M600Ex Fire Detection Range

Our sophisticated Ex system for use in hazardous atmospheres, introduces to the market a range of conventional I.S. fire detectors. In addition to the unobtrusive size and styled shape a number of design features have been incorporated including single visit to the ceiling installation and a service and maintenance detector park position.

MINERVA[®] MX

General

Included within the range is the High Performance Optical Smoke (HPO) Detector and a combined Carbon Monoxide and Heat Detector.

The complete range has been designed to meet the requirements of BS (British Standards) and EN (European Standards) for fire detectors. The detectors also carry the new CE mark.

M600Ex Series Conventional Detectors

The M600Ex Series provides the detector part of an automatic fire detection system, as defined in BS5839 Pt1:2002. The M600Ex Series Conventional or two state detector is one that provides two output states to the controller, either 'normal' or a 'fire alarm' condition.

The detectors along with callpoints are grouped into zones, with each zone being connected to the control panel, by a two wire circuit. Each zone having a separate zone indicator at the control panel. Safety barriers are used to maintain the intrinsically safe status of the circuit under all conditions.

Application

As each type of fire detector responds to a particular 'fire product' the relative speed of response of the detector is therefore dependent upon the type of fire being detected. The range of M600Ex detectors have been designed to provide the earliest possible warning of a fire condition, with a minimum possibility of false/unwanted alarms.

As smoke is normally present at an early stage in most fires, smoke type detectors are therefore considered the most useful. When considering the type of smoke detector for the application, the probable type of fuel for the fire should be considered. For general fire detection, where there is an equal possibility of either a 'fast' or 'slow' fire developing, the intelligent high performance optical detector provides an excellent detection response.

In situations where the installation of smoke detectors would cause an unacceptable level of false alarms (i.e. kitchens, laundry areas) heat detectors may be installed. The M600Ex series provides a selection of heat detectors, from Rate of Rise to fixed temperature.

Because of the wide variety of applications that fire detectors are expected to cover, it is recommended that reference to BS5839 Pt1:2002 is made to aid selection.

MINERVA[®] MX



High Performance Optical Smoke Detector MR601TEx

These detectors react to the whole range of fire products from slow smouldering fires, producing visible particles to open flaming fires producing large numbers of very hot smaller sized aerosols. It combines optical and heat detector technology to detect clear burning fire products which hitherto could only be easily detected by ion-chamber detectors.

For normal ambient conditions, the high performance optical detector behaves as a normal optical detector. Only when a rapid rise in temperature is detected does the sensitivity of the detector increase and the presence of smoke will confirm a fire condition which will be transmitted as an alarm level.



Heat Detector MD601Ex and MD611Ex

These detectors use two networked thermistors in a bridge configuration to provide a fast response, that depends both on absolute temperature and rate of rise of temperature.

The rate of rise/fixed temperature heat detectors can be used in areas where smoke sensors are unsuitable due to environmental conditions (smoke, dust etc.). Such areas include kitchens, locker rooms, canteens, garages, loading bays etc.



Enhanced Carbon Monoxide Fire and Heat Detector MDU601Ex

The MDU601Ex detector is a combined CO and Rate-of-Rise Heat detector where the sensitivity of the CO detector is enhanced in response to a fast rate of change of temperature.

Maybe used in dusty environments instead of the MR601TEx Detector

SPECIFICATIONS

Technical Specifications

Mechanical

Detector Material:	FR 110 "Bayblend" fire resistant
Dimensions:	See diagram below
Weight:	0.2Kg detector and base (approx)
Colour:	White

Environmental

Operating Temp. Range:	-20°C to +70°C -10°C to +55°C (MDU601Ex only)
Storage Temp :	-25°C to +80°C -20°C to +55°C (MDU601Ex only)
Relative Humidity :	95% non condensing 90% non condensing (MDU601Ex only)

Electrical

Supply Voltage:	16 to 28vdc
Quiescent Current:	100µA typical
Alarm Current:	48mA typical
Reset Time:	0.5 - 5 seconds
Wiring Connections:	SEM Terminal 2 x 1.5mm ²

Electromagnetic Compatibility

ESD:	to EN50130-4
Radiated Immunity:	to EN50130-4
Fast Transient:	to EN50130-4
Slow High Energy:	to EN50130-4
Conducted Immunity:	to EN50130-4
Emissions:	to EN61000-6-3

Approvals

These detectors have the following approvals:

LPCB	Loss Prevention Certification Board
VdS	Verband der Sachversicherer

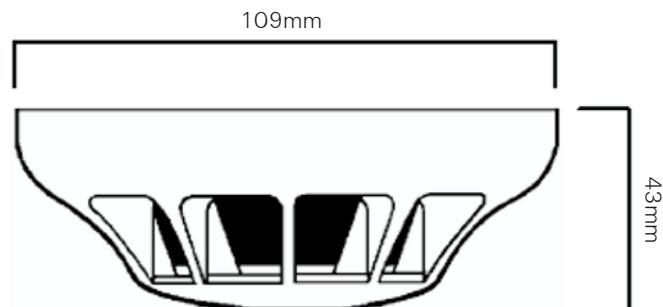

For further information on how we can help you please visit our website at www.tycofis.com or e-mail us on tycofis@tycoint.com. The right is reserved to modify or withdraw any product or service without notice. PSF122TFIS Issue 4 November 2009 © 2009

tyco

*Fire & Integrated
Solutions*

a vital part of your world