

## S200Plus Triple Infra Red Flame Detector

### Triple Waveband Infra-Red Flame Detection

#### Features:

- Unrivalled black body rejection over a wide range of source temperatures
- Triple waveband infra-red solar blind flame detection for optimum false alarm immunity
- Discrimination of optical faults (dirty windows) from other faults in the built-in self test
- Range adjustable to 50 metres for a 0.1m<sup>2</sup> n-heptane pan fire

The MINERVA® S200 PLUS flame detectors are the latest step in over 30 years experience of developing and manufacturing IR, solar blind and multi-channel infra-red flame detectors with low power consumption and high false alarm immunity. The MINERVA® S200 PLUS incorporates the patented dual solar blind feature of the S100 and S200 flame detectors which have had over 26,000 installations world-wide.

The MINERVA® S200 PLUS range of advanced flame detectors is the most comprehensive range available. The devices are available in both Intrinsically Safe or Flameproof versions incorporating a variety of electrical interfaces. All electrical interfaces are supported through the existing range of MINERVA® Fire control panels.

# S271+ Triple Infra Red Flame Detector

## Intrinsically Safe and Flameproof Applications

Unlike other flame detectors on the market the MINERVA® S200PLUS is available in both Intrinsically Safe (EEx ia) and Flameproof (EEx d) models.

The intrinsically safe models are suffixed by the letter "i" and meet the requirements of EN50020 part 7 and are BASEEFA certified EEx ia IIC T5. As part of an intrinsically safe circuit, it is suitable for zones 0, 1 and 2 where group IIC gases or lesser hazards can be continuously present in explosive concentrations.

The flameproof models are suffixed by the letter "f" and meet the requirements of EN50018 and are BASEEFA certified EEx d IIC T6. The detectors are suitable for zones 1 and 2 where group IIC gases or lesser hazards can be intermittently present in explosive concentrations.

## Benefits of the MINERVA® S200 PLUS

- Very low power consumption (0.35mA)
- Models available with Conventional or Analogue Addressable interface (requires 2 core cable only)
- Models also available with relay or 4-20mA outputs
- Patented dual filter solar blindness for complete solar blindness in outdoor use
- Available in Intrinsically Safe and Flameproof variants
- Housing designed for easy installation of cabling
- Flexible mounting and angular adjustment
- 2 x 20mm field cable entries
- IP66/67 housing designed for external use
- Rugged stainless steel ANC4 LM25 alloy housing and mounting bracket
- Operating temperature range of:
  - 20 to +80°C (S200f+) and -40 to +80°C (S200i+) for detectors mounted in a Hazardous Area
  - 40 to +80°C (S200f+/S200i+) when used in a non Hazardous Area
- Variable response times and sensitivity settings
- Remote self test and range setting
- True window test in detection area (i.e. not in the edge of the window)
- Terminals provided for Remote LED connection
- ATEX certified with other approvals for selected models
- Meets the requirements of EN54 Pt 10
- FM Approved Variants
- Designed and manufactured in the UK
- Lloyds Register and DNV approved variants

# S271+ Triple Infra Red Flame Detector

## Performance

The detector is designed to respond in a minimum of 3 seconds, this being the optimum signal processing time constant of the circuitry. Varying sizes of fire will be detected at given distances in the same time and the graph shows the typical ranges for the detection of flames, for given areas of liquid fuels. The time taken by the fire to reach equilibrium depends on the initial temperature of the fuel. If kerosene was pre-heated to a temperature above its flash point, then its behaviour would be equivalent to that of petrol at 25°C

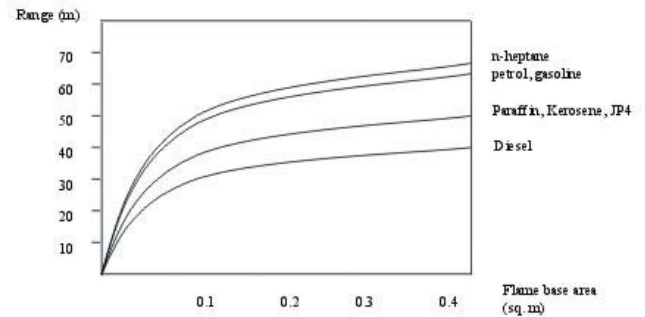

Fig. 1 - Fire Range Test Data

Note: These results are based upon the fire reaching equilibrium rates of combustion in still atmosphere.

## Directional Sensitivity and Range

The polar diagram in figure 2.a shows the directional sensitivity of the intrinsically safe detectors using a 0.1m<sup>2</sup> n-heptane fire. Figure 2b shows the same information for the intrinsically safe detectors using a chopped gas flame. These figures show that maximum detector sensitivity to the extremities of its coverage.

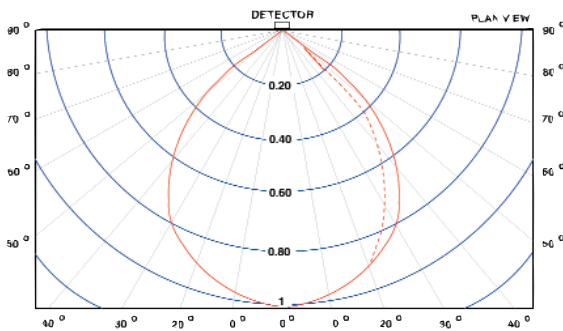

Figure 2a - Pan Fires - Relative Range vs Angle of Incidence. Horizontal Plane Dotted Line Shows Flameproof Version with Steel Guard Fitted Solid Line Shows IS Version

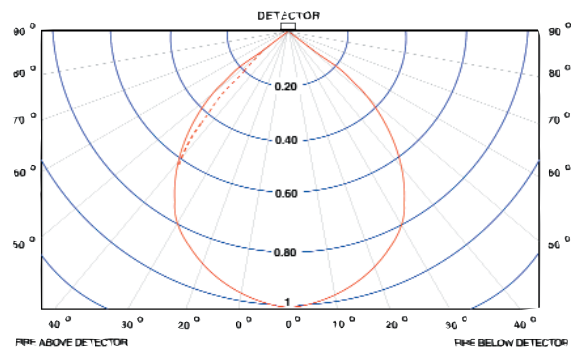

Figure 2b - Pan Fires - Relative Range vs Angle of Incidence. Vertical Dotted Line Shows Flameproof Version with Steel Guard Fitted Solid Lines Shows IS Version

## Typical Response

The MINERVA® S200 PLUS offers a significantly increased sensitivity to flame with the ability to detect a fully developed 0.1m<sup>2</sup> n-heptane pan fire at up to 50m. This increase is made possible by precisely predicting non-flame energy in the flame detection waveband thus enabling discrimination of the signal from a smaller flame. These detectors include three normal standard ranges. Maximum range is 50 m, default range is 25 m and there is a short range of 12.5 m.

## Flame Detection Operation

The MINERVA® S200 PLUS flame detector uses the same, well proven, flame detection techniques employed in other MINERVA IR flame detectors. This is based on monitoring for modulated infra red radiation in the 4.3 m m waveband, which corresponds to CO<sub>2</sub> emission. It incorporates our patented techniques :-

- (a) for improved rejection of solar energy by using a dual 4.3µm filter combination.
- (b) Gaussian noise rejection is achieved by averaging the output signal of two separate sensor elements.

Three separate fire alarm delays of 3 's, 6 's and 12 's are provided in all versions of the MINERVA® S200 PLUS.

# S271+ Triple Infra Red Flame Detector

## Triple IR Blackbody Rejection

The MINERVA® S200 PLUS implements a new concept for eliminating nuisance alarms from modulated black body sources. The design incorporates a novel optical filter which enables a single infra-red sensor to measure the radiated energy present in two separate wavebands placed on either side of the flame detection waveband, at 3.8  $\mu\text{m}$  and 4.8  $\mu\text{m}$  respectively (see fig 3). The signal obtained from this "guard" channel is cross-correlated with the signal from the flame detection channel to provide an accurate prediction of the non-flame energy present in the flame detection waveband. This prediction is independent from the temperature of the radiation source, allowing the MINERVA® S200 PLUS to provide blackbody rejection over a wide range of source temperatures.

The use of an optical processing technique as opposed to the use of two separate electronic sensors improves the overall reliability of the detector by reducing the number of components and eliminating the need for complex calibration procedures during manufacture.

## Built-in self test

The MINERVA® S200 PLUS incorporates a sophisticated self test facility that tests the detector remove for window contamination and electronic circuitry functionality signals. It incorporates two different colour light emitting diodes, and by using differing flash rates, provides separate indication of alarm, detector (electronic) fault and "dirty" window (optical integrity monitoring).

The S241+ and S251+ and S271+ provide separate analog output currents, signalling electronic fault and "dirty" window conditions to their respective control equipment.

## Blackbody Rejection

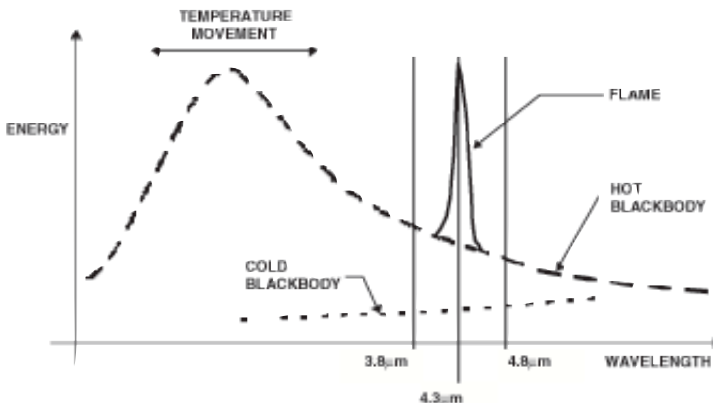

## Flame detection in the presence of blackbody radiation

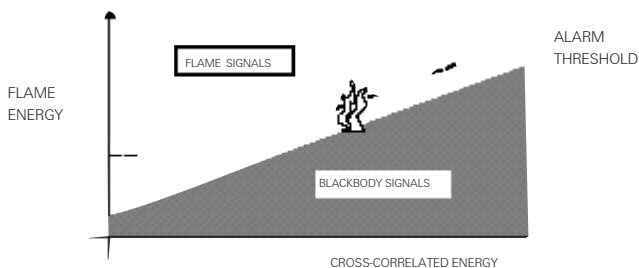

fig. 4. Variable Alarm Threshold

# S271+ Triple Infra Red Flame Detector

## MINERVA S200 PLUS Product Range

Product designation - S2XXx+

3 = Conventional I/f

4 = 4-20mA i/f

5 = Analogue Addressable I/f

6 = Relay Interface

7 = Digital Addressable

1 = BASEEFA certified

2 = FM listed

3 = not used

i = Intrinsically Safe

f = Flameproof

### S23 1i+ and S23Xf + Conventional 2 wire Interface

These models are suitable for connection to a 20V dc current monitored fire alarm controller. This is achieved over a standard two core cable. A wide range of compatible control panels with various land and marine approvals are available. The number of devices permitted on any single detection zone may vary, depending on the control panel to be used. \*

### S24 1i+ and S24 1f+ 4-20mA Current Loop Interface

These models provide a 4-20mA output (current sink) that can be linked to a PLC type logic controller with the pre-set alarm currents provided for electronic fault, optical fault (dirty window), normal and fire alarm conditions. The interface can be achieved over a 3 core cable.

### S25 1i+ and S25Xf+ Analogue Addressable Interface

This unique detector may be interfaced with the LPCB approved MINERVA® and UL/FM approved TFX range of analogue addressable fire control equipment. Communication to these devices is achieved over a 2 core cable. Using the S25 1i+ in conjunction with System 602 (Certification for hazardous areas), up to a maximum of 10\* detectors may be addressed and identified on a single pair of wires within the hazardous area (zone 0).

### System Solutions

The S23X+, S25X+ and S27 1f+ models operate with a variety of MINERVA fire panels which provide interfacing to standard industrial fieldbus protocols such as MODBUS.

### Bracket

The S200PLUS can be bulkhead mounted or for greater flexibility a Stainless Steel 316 bracket provides horizontal and vertical adjustment, thus allowing the detector to be positioned to give an accurate cone of vision to the risk area. The bracket provides axial rotation of 50° and an elevation of 67° refer to fig. 5

### Test Equipment

The MINERVA S200 PLUS is supported by the T2 10+ calibrated IR test source for testing detectors in situ. The T2 10+ test source can be presented to the detectors, using a range of telescopic poles.

Up to 50 off S25 1f+ detectors can be addressed and identified on a single pair of wires within the hazardous area (zone 1). Use of these two models can significantly reduce cabling costs without loss of system integrity.

### S26Xf+ Relay Interface

The S26 1f+ provides a relay interface for alarm and fault condition. The alarm and fault relay can be programmed for either latching or non-latching operation. Both relays are rated 2A at 30V dc.

### S27 1f+ Digital Addressable Interface

This unique detector may be interfaced to the LPCB/VdS Approved Digital Addressable fire control panels. Communication is achieved over a 2 core cable thus providing cost effective installation. Up to 50 off S27 1f+ may be connected to a single digital addressable loop.

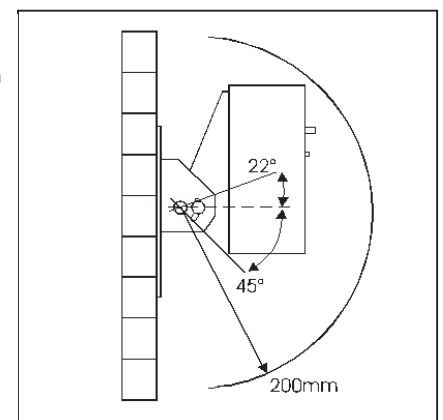

Fig. 5 S200 Mounting Bracket

\* Always consult your supplier with regard to intrinsically safe systems designs.

# S271+ Triple Infra Red Flame Detector

DATA SHEET

## Mechanical

Detector Material	Stainless Steel 316L
Dimension mm	167mmW x 167mmL x 89mmD
Weight	4.5Kg
Gland Entry	3 x 20mm
Metal Parts	Bright Stainless Steel 316 to (external & internal) to BS 1449 Pt 2
Tag Label:	Stainless Steel 316

## Electrical

Supply Voltage	15 to 28 Vdc
Quiescent Current:	
S231i/S23X	350 $\mu$ A max at 20Vdc
S241i/S241f	350 $\mu$ A max at 20Vdc
S251i/S25X	350 $\mu$ A max at 20Vdc
S26X	17 mA max at 20 Vdc
S271f+	Determined by controller
Alarm Current:	
S231i/S231f	33 mA (typical)
S241i/S241f	Signalled on current loop
S251i/S251f	Determined by controller
S261f	30mA (typical)
S271f+	(Quiescent Current) 350 $\mu$ A max at 20Vdc
Connections:	One way 2.5mm heavy duty terminal block
Electrical Interface:	See manual for details

## Environmental

Operating temp	-20 to +80°C (S200f+) and -40 to +80°C (S200i+) for detectors mounted in a Hazardous Area
	-40 to +80°C (S200f+/S200i+) when used in a non Hazardous Area
Storage Temperature	-40°C to + 80°C
Relative Humidity	95% (100% intermittent)
Enclosure to	IP 66 and IP 67

## Performance

Range	0.1m <sup>2</sup> n-heptane at 50m 0.4m <sup>2</sup> n-heptane at 60m
Max Field of View	90° - Flameproof Versions 100° - Intrinsically safe versions
Response Time	Field Selectable 3,6 and 12 seconds.
Sensitivity	3 range settings

## Mounting Bracket

Weight:	1.1 Kg
Construction:	Bright Stainless Steel 316 to BS1449 Pt2
Axial Rotation:	50°
Elevation:	67°
Fixing Details:	M8 bolts (location template provided)

For further information on how we can help you, contact your local ADT office:

### Austria - ADT Austria

Tel: 662 45 24 60 11  
Website: [www.adteurope.com](http://www.adteurope.com)

### Belgium - ADT Security Services SA

Tel: 02 481 08 00  
Website: [www.adt-belguim.be](http://www.adt-belguim.be)

### Czech Republik - ADT Security Center s.r.o.

Tel: 267 267 267  
Website: [www.adt-sc.cz](http://www.adt-sc.cz)

### Denmark - ADT A/S

Tel: 70 80 70 00  
Website: [www.adt-nordic.com](http://www.adt-nordic.com)

### France - ADT France

Tel: 0810 000 260  
Website: [www.adtfrance.fr](http://www.adtfrance.fr)

### Germany - ADT Security Deutschland GmbH

Tel: 0800 7070 238  
Website: [www.adt-deutschland.de](http://www.adt-deutschland.de)

### Greece - ADT Greece SA

Tel: 210 92 43 400  
Website: [www.adt.gr](http://www.adt.gr)

### Hungary - ADT Hungary

Tel: +3614303700  
Website: [www.adthungary.com](http://www.adthungary.com)

### Ireland - ADT Fire and Security plc

Tel: 1620 5888  
Website: [www.adt.ie](http://www.adt.ie)

### Italy - ADT Italy

Tel: 02 818061  
Website: [www.adtitaly.com](http://www.adtitaly.com)

### The Netherlands - ADT Security Services B.V.

Tel: 010 258 4848  
Website: [www.adt-security.nl](http://www.adt-security.nl)

### Norway - ADT AS NUF

Tel: 81 55 88 88  
Website: [www.adt-nordic.com](http://www.adt-nordic.com)

### Poland - ADT Poland Sp. Z o.o.

Tel: 0 801 801 238  
Website: [www.adt.pl](http://www.adt.pl)

### Portugal - ADT Portugal

Tel: 217 510 560  
Website: [www.adt-pt.com](http://www.adt-pt.com)

### Russia - ADT Russia

Tel: +7 (495) 661 2094  
Website: [www.adtrussia.com](http://www.adtrussia.com)

### Spain - ADT Servicios de Seguridad SL

Tel: 902 444 440  
Website: [www.adt-es.com](http://www.adt-es.com)

### Sweden - ADT AB

Tel: 8 40 00 70 00  
Website: [www.adt-nordic.com](http://www.adt-nordic.com)

### Switzerland - ADT Switzerland

Tel: 0848 40 08 01  
Website: [www.adt-ch.com](http://www.adt-ch.com)

### United Kingdom - ADT Fire & Security plc

Tel: 0800 010 999  
Website: [www.adt.co.uk](http://www.adt.co.uk)

